

STAT1 Series Dual Power Automatic Transfer Switch Operating Manual

Standard: G B/T 14048.11
IEC 60947-6-1

Before installing and using the product,
please read the instruction manual carefully,
and keep it in a safe place for future use.

STATS1-100~3200GA1/GA

PC. AUTOMATIC TRANSFER SWITCH



Product Type

Enterprise code	Product category	Design code	Current frame	Product code	No. poles	Rated current	Working mode	Additional function
STAT	- S	1	100	GA1/GA /	3P	100A	R	F

Name	Details		
Enterprise code	Ström Electric		
Product category	PC class automatic transfer switch		
Design code	1		
Current frame	Product code	Current frame	
	GA	100A,160A,250A,400A,630A,1000A,1250A,1600A,2000A,2500A,3200A	
Product code	Product code	Working current	Features
	GA1	16A~100A	Economical type
	GA	16A~3200A	Integral type, 3 positions, with fire-fighting function
Pole	3P ,4P		
Rated current	16A~3200A		
Working mode	R=Self-input and self-recover		
Additional function	F: Utility- Generator		

Technical parameter

Type	STATS1-GA1, STATSA-GA																									
Current frame	100				250				630				1600				3200									
Rated working current (Ie)	16	20	25	32	40	50	63	80	100	125	160	200	225	250	315	350	400	500	630	800	1000	1250	1600	2000	2500	3200
Rated insulation voltage (Ui)	690V												800V													
Rated impulse withstand voltage (Uimp)	8kV																									
Rated working voltage (Uw)	AC400V																									
Use category	AC-33B																									
Rated limited short circuit current (Icm)	8kA				17kA				26kA				67.5kA													
Rated short-time withstand current (Icw)	5kA/30ms				10kA/60ms				12.6kA/60ms				32kA/60ms													
Transfer time	2.5s				2.2s				0.9s				2s													
Control power voltage	DC24V, AC110V, AC220V																									
Rated frequency	Start	11W				13W				355W				400W				440W				600W				
	Normal									74W				90W				98W				120W				
Mechanical life	6000				6000				3000				3000				2000									
Electrical life	1500				1000				1000				500				500									

STATS1-100~3200GA1/GA

PC. AUTOMATIC TRANSFER SWITCH

Appearance and Installation Dimensions

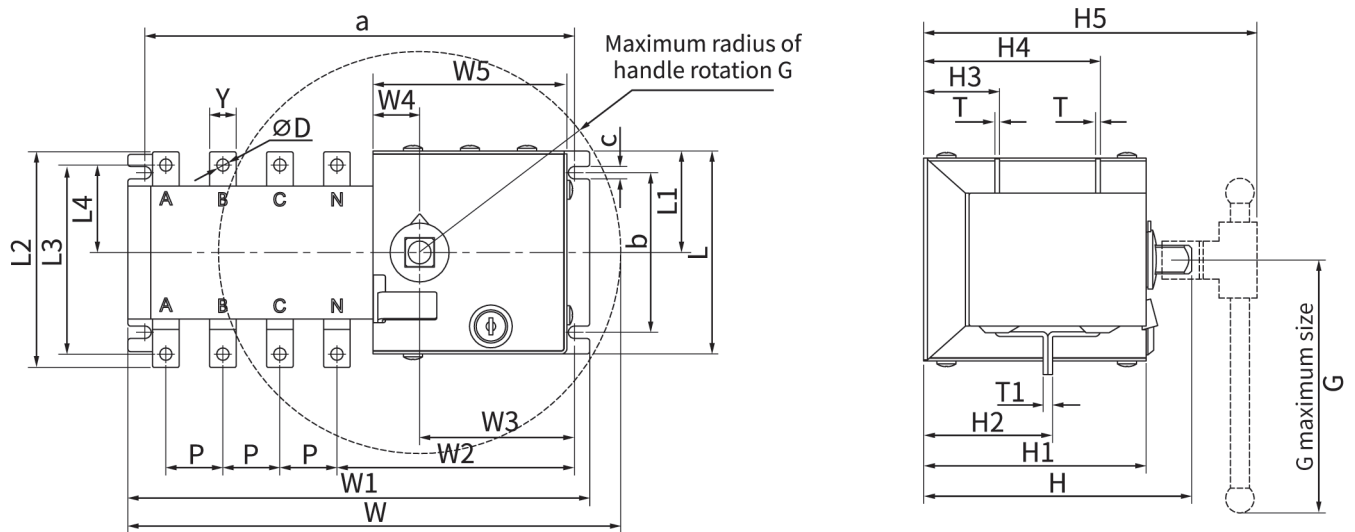

Dimensions (mm)		STA-ST2-100	STA-ST2-250	STA-ST2-400	STA-ST2-630
Installation Size	a	223.5	347	410	410
	b	83.5	102	180	180
	c	6.5	7	9	9
	W	270	412	580	580
	W1	243	368	435	435
	W2	123	165	180	180
	W3	82	91	88.5	88.5
	W4	24.5	35	45	45
	W5	102	115	124	124
	P	30	50	65	65
	Y	14	25	40	40
	ØD	6.5	10	12	12
	L	106.8	121.5	161	161
	L1	53.5	77	86	86
	L2	114	170	266	266
	L3	99.5	144.5	230	230
	L4	46	78	112.5	112.5
	H	141	194	268	268
	H1	117	163	237	237
	H2	68	57	83	83
	H3	40	57	83	83
	H4	93	130	193	193
	H5	170	225	297	297
	T	2.5	3.5	6	6
	T1	5	3.5	6	6
	G	115	144	250	250

STATS1-100~3200GA1/GA

PC. AUTOMATIC TRANSFER SWITCH



Switch Structure Description

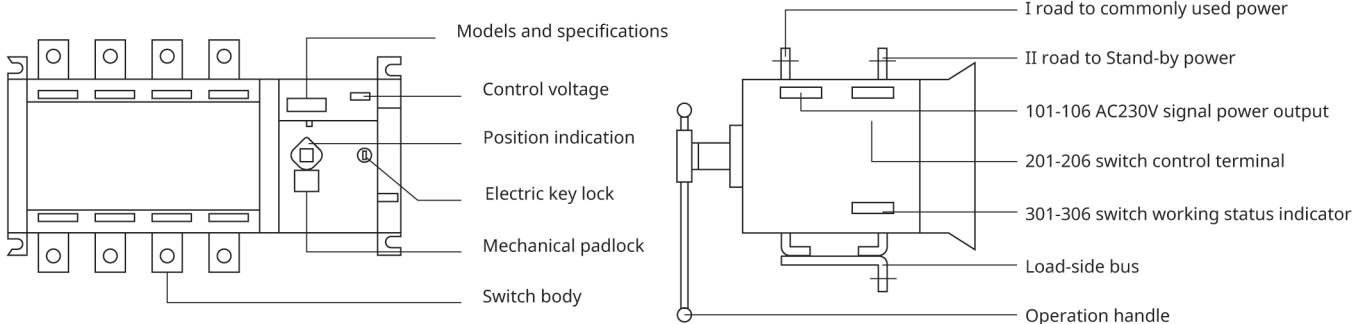

Electric Key Lock

The electric key lock controls the internal power supply of the switch's control circuit.

- When the electric lock is activated, the switch enables automatic and remote operation.
- When the electric lock is deactivated, the switch can only be operated manually.

Operation Handle

To manually operate the switch using the operation handle, the electric lock must be closed.

Mechanical Padlock

During maintenance:

- Use the operation handle to set the switch to the 0 position.
- Lift the padlock mechanism and attach a mechanical padlock before beginning maintenance.
- Engaging the padlock cuts off the internal control power, preventing the switch from being energized or operated manually.

Position Indication

The switch's operational status is indicated by the following positions:

- I (Main power supply active)
- 0 (Neutral/off position)
- II (Standby power supply active)

Control Voltage

The switch control voltage level is 220V AC.

Switch Body

- The front section (I) connects to the main power supply.
- The rear section (II) connects to the standby power supply.

Component Specifications

Component	Description	
Control Voltage	220V AC	
Position Indication	I, 0, II	
Electric Key Lock	Enables automatic/remote or manual operation	
Mechanical Padlock	Secures the switch in maintenance mode	
Switch Body	Connects to main and standby power sources	
Terminals	101-106	AC230V signal power output terminal
	201-206	Switch control terminal
	301-306	Switch working status indication
Load-Side Bus	Distributes power to the load	
Operation Handle	Allows manual switch control	

STATS1-100~3200GA1/GA

PC. AUTOMATIC TRANSFER SWITCH



Installation and Wiring Instructions



STATS1 Wiring method

Wiring Procedure:

At the input terminals of the switch:

- Connect the main power supply to terminals A, B, C, N.
- Connect the standby power supply to terminals A, B, C, N.
- For 2-pole products, connect L and N.

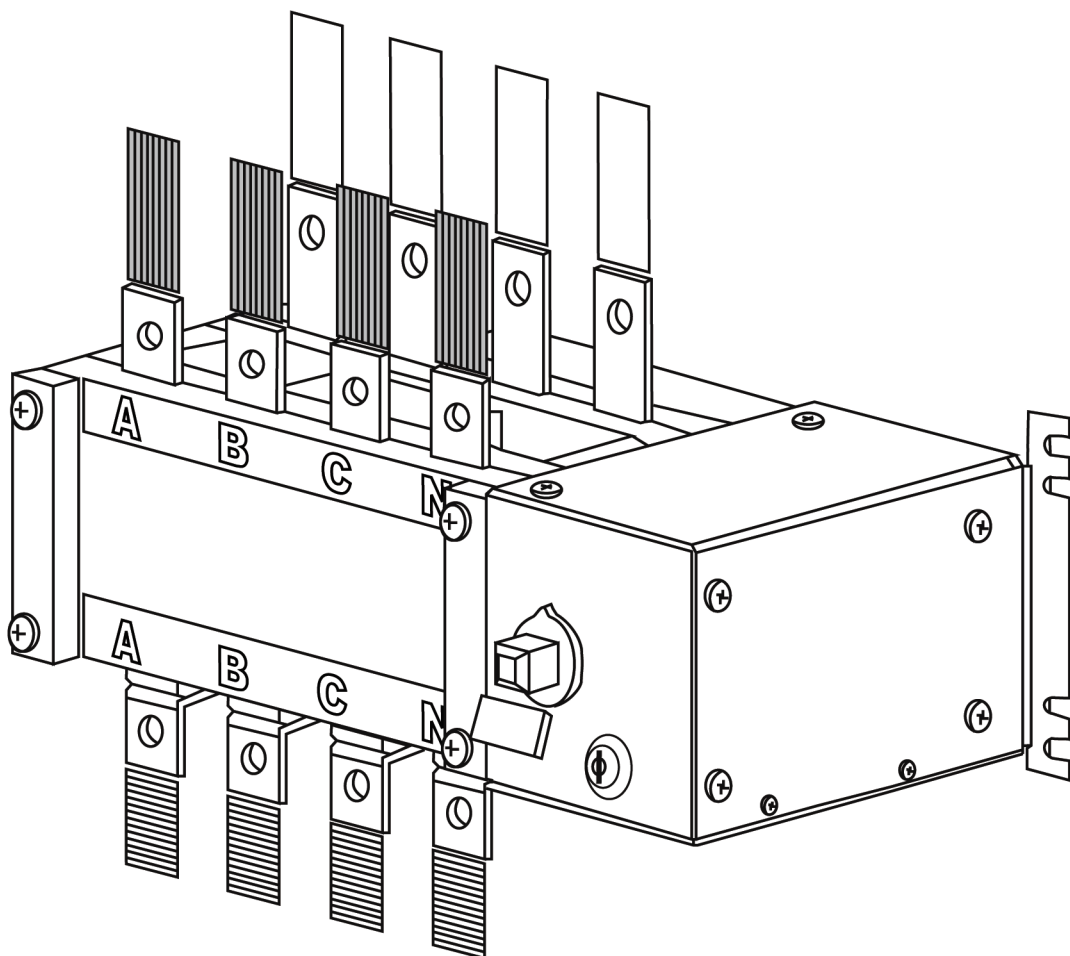

 II Power Supply
(Common)

 I Power Supply
(Standby)

 Load side

STATS1-100~3200GA1/GA

PC. AUTOMATIC TRANSFER SWITCH



Installation and Wiring Instructions

Automatic Wiring Mode

- The key lock must be set to "Auto" mode, and the mechanical padlock must not be engaged.
- When in "Auto" mode, fire control double-separation is functional.
- In "Auto" mode, manual operation using the handle is prohibited.

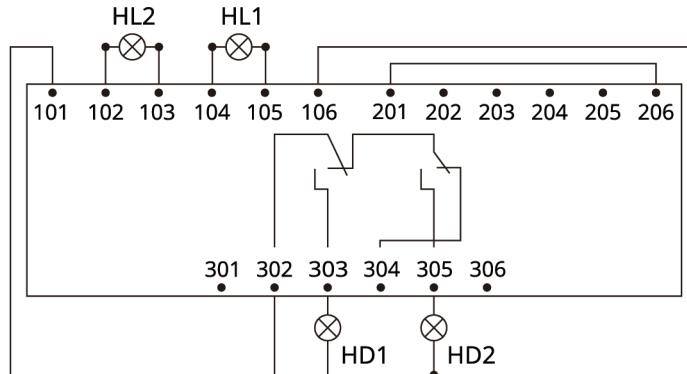

•HL1 refers to the indicator of the common power supply;
•HL2 refers to the indicator of the standby power supply.

•HD1 refers to the turn-on indicator of the common power supply;
•HD2 refers to the turn-on indicator of the standby power supply.

Wiring for Status Indicators:

1. Connect any live wire **L** (A, B, or C) from the switch output to terminal 302.
2. Connect one end of the main power indicator to terminal 303 and the other end to the **N** output line.
3. Connect one end of the standby power indicator to terminal 305, and the other end to the **N** output line.

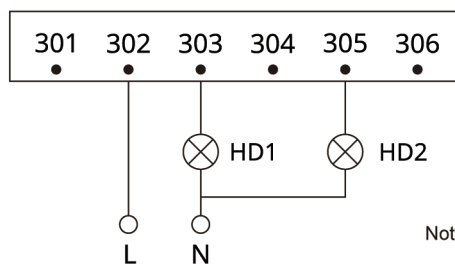

Note: L and N come from the output of the main circuit of the switch

Fire Control Double-Separation Wiring:

- Set the key lock to "Auto" mode.
- Short terminals 301 and 306 to activate double-separation mode.

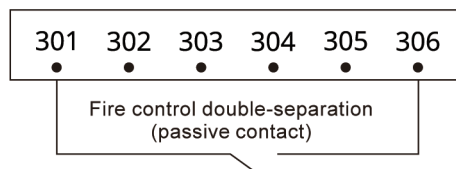

STATS1-100~3200GA1/GA

PC. AUTOMATIC TRANSFER SWITCH



Installation and Wiring Instructions

Manual Wiring Mode

- The key lock must be set to "Manual" mode, and the mechanical padlock must not be engaged.
- The handle can only be used when in manual mode.

- Fire control double-separation wiring diagram is as follows.

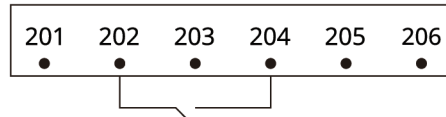

Fire control double-separation (passive contact)

Remote Control Wiring Mode

- The key lock must be set to "Auto" mode, and the mechanical padlock must not be engaged.
- When the key lock is set to "Auto" mode, manual operation using the handle is prohibited.
- Do not short-circuit terminals 201 and 206 when wiring for remote control, as this will cause the switch to default to automatic mode.

Remote Wiring Instructions:

1. Connect remote control components according to the circuit diagram.
2. Ensure proper connection of the fire control double-separation (passive contact).
3. Test SB1 and SB2 buttons:
 - Press SB1 → The switch should transfer to **I** (Main power supply).
 - Press SB2 → The switch should transfer to **II** (Standby power supply).
4. Verify that the respective status indicators illuminate accordingly.

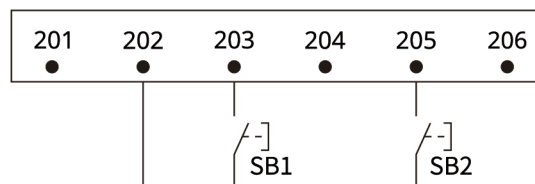

•SB1 and SB2 are the manual power-on button (passive contact) for common power and standby power.

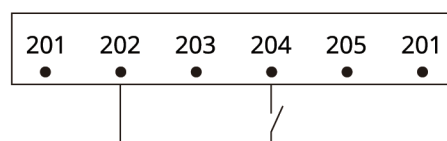

Fire control double-separation (passive contact)

STATS1-100~3200GA1/GA

PC. AUTOMATIC TRANSFER SWITCH



Installation and Wiring Instructions

Terminal Wiring Operation

Press the terminal in the indicated direction to embed the wires securely.

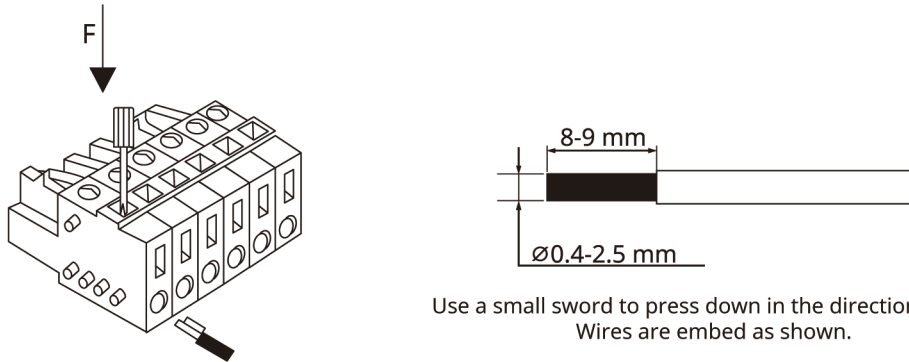

Use a small sword to press down in the direction shown.
Wires are embed as shown.

Switch Installation Method

Ensure proper alignment and secure installation. Refer to diagrams for correct positioning.

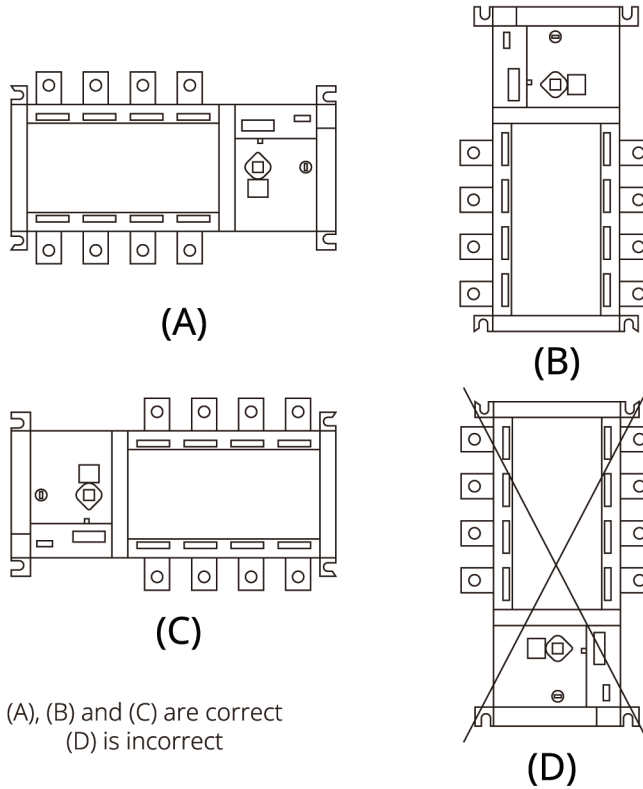

(A), (B) and (C) are correct
(D) is incorrect

STATS1-100~3200GA1/GA

PC. AUTOMATIC TRANSFER SWITCH

Installation and Wiring Instructions

Switch Testing and Debugging

Automatic Testing

1. Start
2. Are both power sources available? → If Yes, go to Step 3. If No, go to Step 5.
3. Set switch to position I (Main Power Active)
4. Monitor power status
5. Did the main power supply fail? → If Yes, go to Step 6. If No, return to Step 3.
6. Transfer switch to position II (Standby Power Active)
7. Is the main power supply restored? → If Yes, go to Step 8. If No, remain in position II.
8. Switch reverts to position I (Main Power Active)
9. End

Remote Control Testing

- Press SB1: The switch should transfer to I.
- Press SB2: The switch should transfer to II.
- When active, the respective status indicators should illuminate.

Warranty and Company Policy

The company provides a 24-month warranty from the date of manufacture, covering defects in materials and workmanship. The warranty does not cover:

1. Improper usage, maintenance, or storage.
2. Unauthorized modifications or repairs.
3. Damage from installation mishandling.
4. Natural disasters, abnormal voltage, or external accidents.

For any warranty claims or service inquiries, contact:

IMPORTADORA OTECE
Av. 10 de Agosto N34-81 y Juan Bayas, Quito, Ecuador
Tel: +593-022-457470
Email: info@otece.com.ec

